

DIGITAL TWIN INTERNAL LOGISTICS AI AND ROBOTS TO SUPPORT OPERATORS

To allow dynamic management of internal logistics, the plant manager receives proposals for solutions and relevant decision-making aids to anticipate risks in crisis management and improve productivity.

SIMULATE

OPTIMISE

SUPPORT



ALTEN end-to-end support tailored to the business context

Simulate

- Scheduling
- Logistic flows
- Operators flows
- Tool and AGVs flows
- Factory control tower (performance measurement)

Optimise

- Real time flow supervision
- Automation of simulations (past, present and future)
- Supervised simulation using artificial intelligence and distributed Multi-Robot Task Allocation algorithms
- Optimisation research to find the best solutions for task allocation between human and machines
- Prescription of added-value logistics scenarios

Support the optimisation of internal logistics flows and the crisis management

- The plant manager receives analysis to understand and decide:
 - The plant performance and risks
 - The current crisis (if applicable), and the causes of failures
 - Possible measures and associated gains
- Operators and robots receive instructions to implement the new strategy selected by the pilot
- Effectiveness of prescriptions is measured, and the system learns from its experiences (Reinforcement Learning)
- Operators are guided in augmented reality to be trained or to carry out work instructions

ALTEN supports its customers' development strategies in the areas of innovation, R&D and technological information systems. Created more than 30 years ago, the Group has established itself as a world leader in Engineering and IT Services. Based in 30 countries, ALTEN currently has more than 54,100 employees all over the world.



ALTEN

ALTEN SUPPORT FOR THE IMPLEMENTATION OF THE DIGITAL TWIN

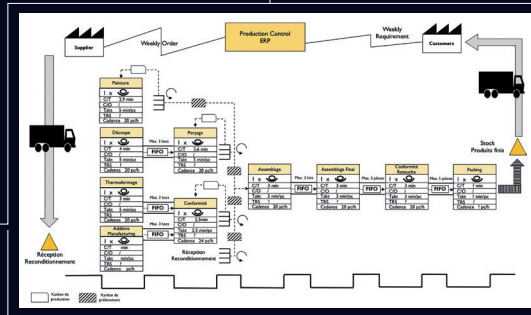
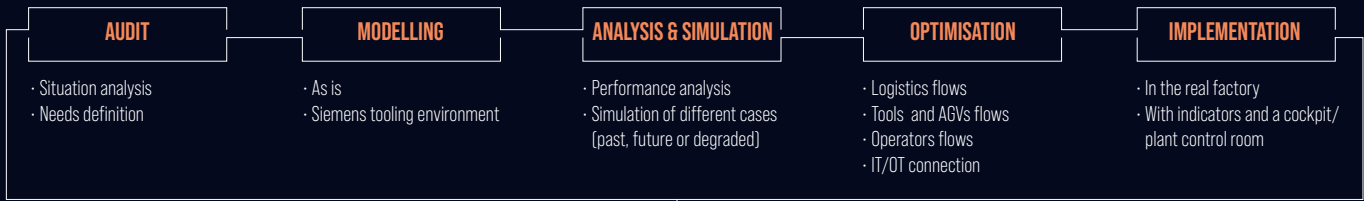

TO GO FURTHER Multi-Robot Task Allocation (MRTA)

MRTA is the problem of optimally assigning a set of tasks to a set of robots, given certain constraints.

Our approach aims at optimising the performance of the fleet and the production system by taking into account:

- The centralised or distributed aspect (embedded in each of the robots) of these calculations
- The heterogeneous aspect of the fleet of robots, which may be of different brands and capacities of action
- The complex aspect of the tasks to be performed (scheduling of simple tasks with more complex tasks incorporating the robot/human cooperative dimension)



LEARN MORE
HUMAN AT THE HEART OF FACTORY 4.0

CONTACT

Jean-Luc CLAVEL - jean-luc.clavel@alten.com

OUR PARTNERS

SIEMENS



ALTEN